

Models:

GAC500 / GAC600 / GAC750 / GAC900

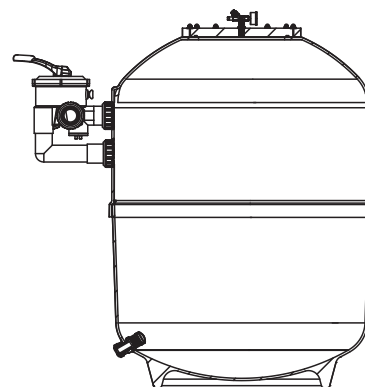

FUNCTION

The filter uses special filter sand to remove dirt particles from pool water. The filter sand is loaded into the filter tank and functions as a permanent dirt removing media. When the control valve is in the FILTER position, the pool water which contains suspended dirt particles, is pumped through your piping system and is automatically directed by the patented filter control valve to the top of the filter tank. As the pool water is pumped through the filter, dirt particles are trapped by the sand bed, and filtered out. The cleaned Pool water is returned from the bottom of the filter tank, through the control valve and back to the pool through the piping system. This entire sequence is continuous and automatic. It provides for total recirculation of pool water through your filter and piping System.

After a period of time, the accumulated dirt in the filter causes a resistance to flow, and the flow diminishes. This means it is the time to clean your filter. With the control valve in the BACKWASH position, the water flow is automatically reversed through the filter so that it is directed to the bottom of the tank, up through the sand, flushing the previously trapped dirt and debris out the waste line. Once the filter is back-washed of dirt, set control valve to RINSE position and run pump for about 1/2 to 1 minute, and then set the control valve in the FILTER position, to resume normal filtering.

NOTE: Turn pump off before changing valve position.

INSTALLATION

Pipe sealant for plastic adapters are required to install and service the filter.

- 1) The filter should be placed on a level concrete slab, very firm ground, or equivalent. Position the filter so that the piping connections, control valve are convenient and accessible for operation and service.
- 2) Loading the sand media. Filter sand media is loaded through the top opening of the filter.
 - a) Place two O'ring on the side of the filter tank and Connect control valve to the filter using pipes with unions and glues.
 - b) Loosen the nuts and remove the acrylic cover.
 - c) We recommend filling tank approximately 1/3 way with water to provide a cushion effect when the filter sand is poured in. This helps protect the under-drain laterals from excessive shock.
 - d) Carefully pour in correct amount and grade of filter sand. Sand surface should be leveled and should come to about the middle of the filter tank.
- 3) Install the valve. Tighten the nuts and install the acrylic cover.
 - a) Carefully screw the T-shape Exhaust Switch onto the filter lid and make sure there do not over-tighten.
 - b) Ensure T-Shape Exhaust switch is tight fit to filter lid and turn it easily.
- 4) Connect pump to control valve opening marked PUMP.
- 5) Make return to pool pipe connection to control valve opening marked RETURN and complete other necessary plumbing connections, suction lines to pump, waste, etc.
- 6) Make electrical connections to pump per pump instructions.
- 7) To prevent water leakage, be sure all pipe connections are right.

INSTALL/START-UP OF FILTER

- 1) Be sure correct amount of filter media sand is in tank and that all connections have been made and are secure.
- 2) Depress control valve handle and rotate to BACKWASH position. (To prevent damage to control valve seal, always depress handle before turning.)
- 3) Prime and start pump according to pump instructions (be sure all suction and return lines are open), allowing the filter tank to fill with water. Once water is flowing out of the waste line, run the pump for at least 1 minute. The initial back-washing of the filter is recommended to remove any impurities or fine sand particles in the sand media.
- 4) Turn pump off and set valve to RINSE position. Start pump and operate until water in sight glass is clear, about 1/2 to 1 minute. Turn pump off and set valve to FILTER position and restart pump. The filter is now operating in the normal filter mode, filtering dirt particles from the pool water.
- 5) Adjust pool suction and return valves to achieve desired flow. Check system and filter for water leaks and tighten connections, bolts, nuts, as required.
- 6) Note the initial pressure gauge reading when the filter is clean. (It will vary from pool to pool depending upon the pump and general piping system.) As the filter removes dirt and impurities from the pool water, the accumulation in the filter will cause the pressure to rise and flow to diminish. When the pressure gauge reading is 1.5 bar, higher than the initial "clean" pressure you noted, it is time to backwash the filter (see BACKWASH under filter and control valve functions).

NOTE: During initial clean-up of the pool water it may be necessary to backwash frequently due to the unusually heavy initial dirt load in the water.

MAIN DIMENSION

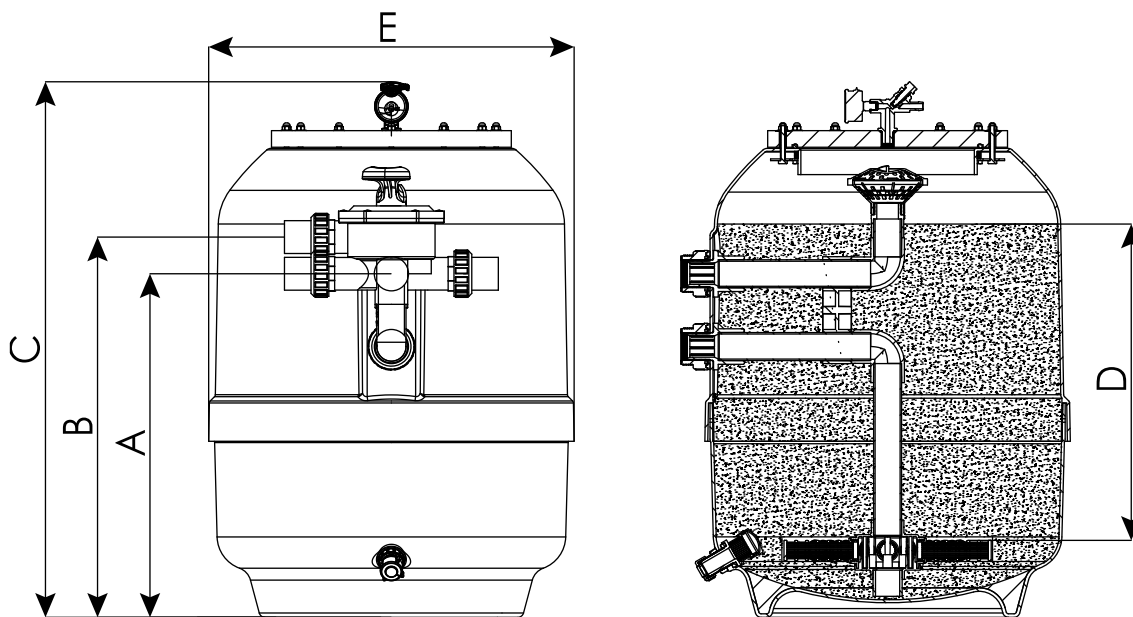

Code	Model	Filter Area		Max Flow Rate			Sand		In/Outlet Connections		A mm	B mm	C mm	D mm	E mm
		ft ²	m ²	gpm	lpm	m ³ /h	lbs	kgs	GB(mm)	ANSI					
9015704	GAC500	2.1	0.2	44	166	10	220	100	GB50	1.5"	510	573	822	310	526
9015701	GAC600	3	0.28	62	233	14	440	200	GB50	1.5"	590	653	920	420	627
9015702	GAC750	4.7	0.44	97	367	22	1060	480	GB63	2"	880	966	1211	650	782
9015703	GAC900	6.9	0.64	141	531	32	1655	750	GB63	2"	964	1050	1334	725	922

PARTS OF 1.5" VALVE

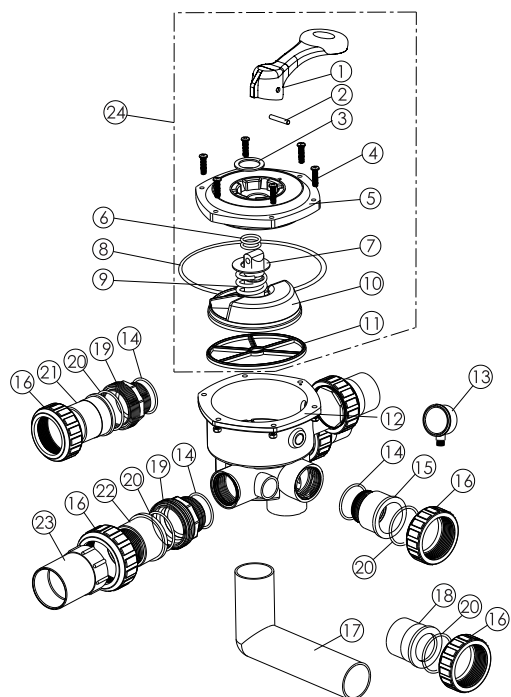

Item	Part No.	Description	Qty
1	01013003	Handle (Big)	
2	03018008	Pin for Handle	1
3	01181001	Washer for Handle	1
4	89280107	M6 x 30 Screw with Nut for Standard Lid	6
5	01013154	1.5" Top/Side Mount Valve Standard Lid (Black)	1
6	02011022	O-Ring for Valve Rotor	2
7	01181002	Washer for Spring	1
8	02011002	O-Ring for 1.5" Valve Lid	1
9	03014001	Spring	1
10	01021001	1.5" Valve Rotor	1
11	02311002	Spider Gasket	1
12	430129058	Bottom Body (Black)	1
13	06011032	Oil Pressure Gauge with O-ring (40psi)	
14	02020013	O-Ring	4
15	01013018	1.5" Union Tale (Black)	1
16	01013017	1.5" Union Nut (Black)	5
17	01013116	1.5" Elbow Tube (Black) 125mm	1
18	01171002	1.5" Union Adaptor (Metric)	1
19	01013015	1.5" Connector (Black)	3
20	02011003	O-Ring for 1.5" adaptor	5
21	01171153	1.5"Union (A/E)	3
22	01041002	1.5" Union with Sight Glass (Short)	1
23	01172026	1.5" Union with Sight Glass Holder	1
24	919305061	MPV01/MPV03 Upper part	1

PARTS OF 2.0" VALVE

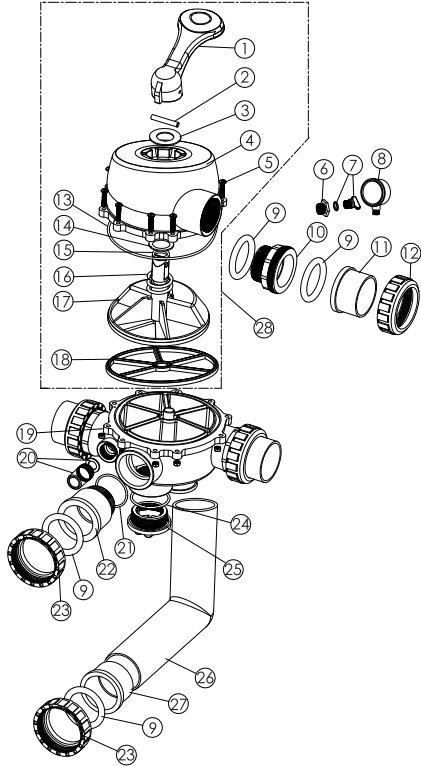

Item	Part No.	Description	Qty
1	01013003	Handle (Big)	1
2	03018008	Pin for Handle	1
3	01181001	Washer for Handle	1
4	01013156	Squareness Lid (Black)	1
5	E190143	M6 x 30 Screw with Nut	10
6	89280120	Drain Plug Fitting with O-ring	1
7	89021307	Drain Plug with O-Ring	1
8	06011032	Oil Pressure Gauge with O-ring (40psi)	1
9	02020016	O-Ring for Connector	8
10	01013031	2.0" Connector (Black)	3
11	01171154	2.0" Union (A/E)	3
12	01013032	2.0" Union Nut (Black)	3
13	02011009	O-Ring for 2.0" valve Lid	1
14	01181002	Washer for Spring	1
15	02011022	O-Ring for Valve Rotor	2
16	03014014	Spring for Valve	1
17	01021002	2.0" Valve Rotor	1
18	02311003	Spider Gasket	1
19	01013026	Bottom Body (Black)	1
20	89280104	Sight Glass with O-Ring	1
21	02020018	O-Ring for Union Tale	1
22	01013099	2.0" Union Tale (Black)	1
23	01013034	2.0" Union Nut (Black)	2
24	02020017	O-Ring for Plug	1
25	01013101	2.0" Side Mount Valve Plug (Black)	2
26	01013148	2.0" Elbow Tube 130mm (Black)	1
27	01171035	2.0" Union Adaptor (Metric)	1
28	919301017	MPV04 Upper part	1

REPLACEMENT PARTS OF FILTER

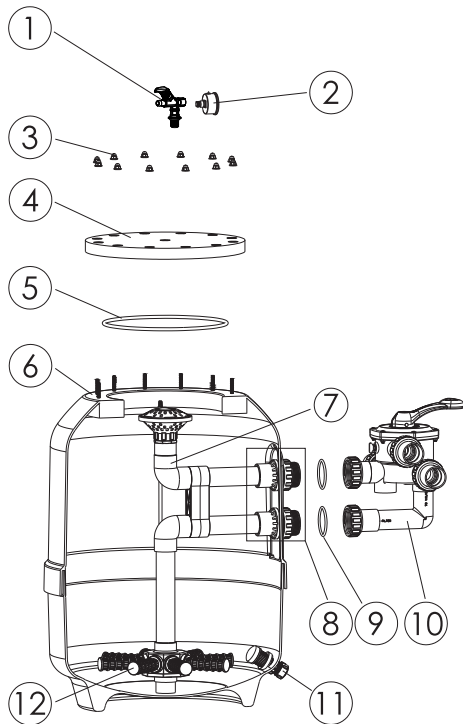

1	40108008	GAC Exhaust Switch	1
2	117043349	Oil Pressure Gauge (40 psi)	1
3	E015708	GAC M8 nut with gasket	12
4	1011910508	Cover D412X30mm	1
5	111000064	O-Ring for Cover D325X8	1
6	E0115705	GAC500 Fiter Tank	1
	E0115706	GAC600 Fiter Tank	1
	E0115707	GAC750 Fiter Tank	1
	E0115708	GAC900 Fiter Tank	1
7	E015701	GAC500 of the Inner Tank System	1
	E015702	GAC600 of the Inner Tank System	1
	E015703	GAC750 of the Inner Tank System	1
	E015704	GAC900 of the Inner Tank System	1
8	E011605	1.5" Connector Sets (GAC500/GAC600)	2
	E011610	2" Connector Sets (GAC750/GAC900)	2
9	111142575	O-Ring D57.4Xd50.8X3.3 (GAC500/GAC600)	2
	111040008	O-Ring D70Xd60X6 (GAC750/GAC900)	2
10	91901549	1.5" Side Mount Valve (GAC500/GAC600)	1
	91902549	2" Side Mount Valve (GAC750/GAC900)	1
11	E010406	Water Drain Set	1
12	4107210652	Laterals 115mm (GAC500)	8
	4107210654	Laterals 126mm (GAC600)	8
	4107210657	Laterals 185mm (GAC750)	8
	4107210676	Laterals 233mm (GAC900)	8

FUNCTIONS OF VALVE POSITIONS

Valve Position	Function
FILTER	Normal Filtration
BACKWASH	Cleaning Filter by reversing the flow
RINSE	Used after backwash to flush dirt from valve
WASTE	By-passes filter, used for vacuuming to waste or lowering water level
RECIRCULATE	By-passes filter for circulating water to pool
CLOSED	Shuts off all flow to filter or pool

FILTER
WASTE

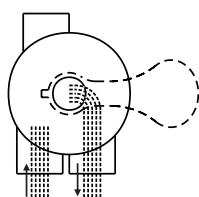

IN FLOWOUT FLOW

WASTE
WASTE

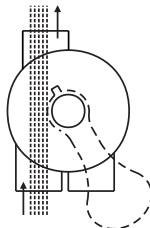

IN FLOWOUT FLOW

CLOSED
WASTE

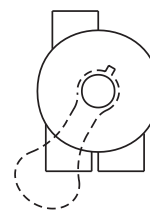

IN FLOWOUT FLOW

BACKWASH
WASTE

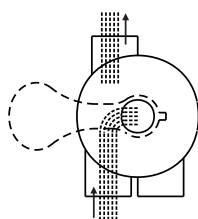

IN FLOWOUT FLOW

RINSE
WASTE

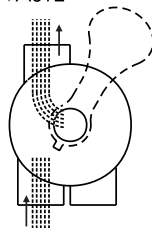

IN FLOWOUT FLOW

RECIRCULATE
WASTE

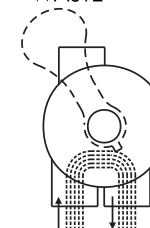

IN FLOWOUT FLOW

GENERAL

- 1) Pipe tap boss provided for optional influent pressure gauge.
- 2) SERVICING VALVE (Stop pump, close gate valve in suction & discharge before proceeding):
 - a) Set handle in filter position.
 - b) Remove cover screws.
 - c) Lift cover and key assembly out.

TO ASSEMBLE:

- 1) Place valve key so that wedge opening is at TOP port (handle in Filter psn.). Flat edge of cover screw lug should align with flat edge of body screw lug.
- 2) Position cover O'Ring.
- 3) Secure assembly to body with cover screws. Tighten cover screws evenly and alternately. Do not over-tighten.

WARNING

- ⚠ THIS FILTER OPERATES UNDER HIGH PRESSURE. WHEN ANY PART OF THE CIRCULATING SYSTEM (e.g., CLAMP, PUMP, FILTER, VALVES, ETC.) IS SERVICED, AIR CAN ENTER THE SYSTEM AND BECOME PRESSURIZED. PRESSURIZED AIR CAN CAUSE THE LID OR VALVE TO BE BLOWN OFF WHICH CAN RESULT IN SEVERE INJURY, DEATH, OR PROPERTY DAMAGE. DO NOT UNSCREW SCREWS OF FLANGE CLAMP WHILE FILTER OPERATING.
- ⚠ TURN PUMP OFF BEFORE CHANGING VALVE POSITION.
- ⚠ TO PREVENT DAMAGE TO THE PUMP AND FOR PROPER OPERATION OF THE SYSTEM, CLEAN PUMP STRAINER AND SKIMMER BASKETS REGULARLY.
- ⚠ UNDER LOW TEMPERATURE SHUT OFF CONDITION, IT IS STRONGLY RECOMMEND TO TURN TO WINTERISE POSITION AND DISCHARGE ALL THE WATER INSIDE FILTER THROUGH THE BOTTOM DRAIN.