

EM-VALVE FOR "ULTRA" REPLACEMENT PARTS

Key No.	Part No.	Product Description	Qty
1	01013130	Handle for 1.5" 4-way Valve	1
2	03018160	Pin for handle	1
3	01013131	Fixation for 1.5" 4-way Valve Handle	1
4	03011003	4 *12 Self-drilling screw	3
5	01013132	Pressing Ring	1
6	01181060	Washer for 1.5" 4-way Valve Handle	1
7	02011095	O-Ring for Rotor	2
8	02311010	Spider Gasket	1
9	06021014	Plastic pressure gauge With O-Ring (8Psi)	1
10	01013134	1.5" 4-way Valve Body	1
11	89280104	Sight Glass with O-Ring	1
12	01013137	1.5" 4-way Valve Rotor Connector	1
	01013133	Rotor for 1.5" 4-way Valve	1
	01013135	Diffuser for 1.5" 4-way Valve	1
13	02011184	O-Ring for Diffuser	1

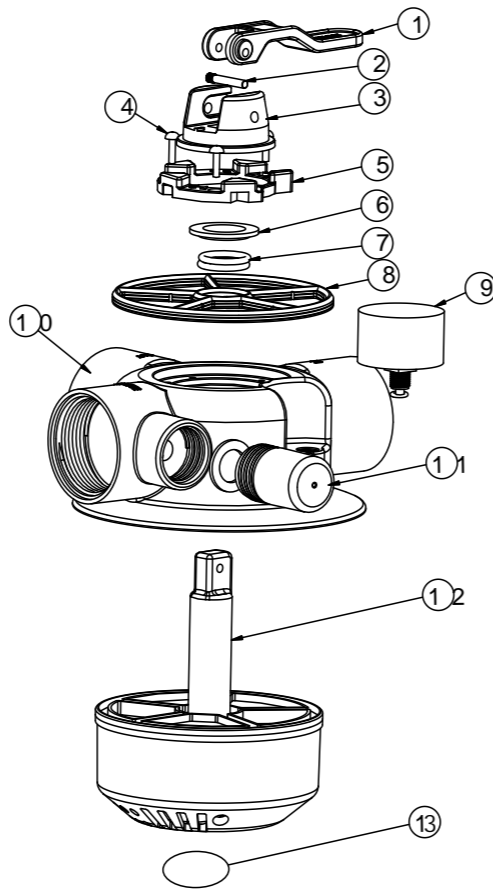

Valve Position	Function
FILTER	Normal Filtration and Vacuuming
BACKWASH	Cleaning Filter by reversing the flow
RINSE	Used after backwash to flush dirt from valve
WASTE	By-passes filter, used for vacuuming to waste or lowering water level
RECIRCULATE	By-passes filter for circulating water to pool
CLOSED	Shuts off all flow to filter or pool

WARNING

- ⚠ THIS FILTER OPERATES UNDER HIGH PRESSURE. WHEN ANY PART OF THE CIRCULATING SYSTEM (e.g., CLAMP, PUMP, FILTER, VALVES, ETC.) IS SERVICED, AIR CAN ENTER THE SYSTEM AND BECOME PRESSURIZED. PRESSURIZED AIR CAN CAUSE THE LID OR VALVE TO BE BLOWN OFF WHICH CAN RESULT IN SEVERE INJURY, DEATH, OR PROPERTY DAMAGE
- ⚠ TURN PUMP OFF BEFORE CHANGING VALVE POSITION.
- ⚠ TO PREVENT DAMAGE TO THE PUMP AND FOR PROPER OPERATION OF THE SYSTEM, CLEAN PUMP STRAINER AND SKIMMER BASKETS REGULARLY.
- ⚠ DO NOT UNSCREW SCREWS OF FLANGE CLAMP WHILE PUMP IS RUNNING.

FSU-4TP FSU-4P FSU-6TP FSU-6P FSU-8TP FSU-8P

FILTER & PUMP COMBO
Installation & Operating
Instruction

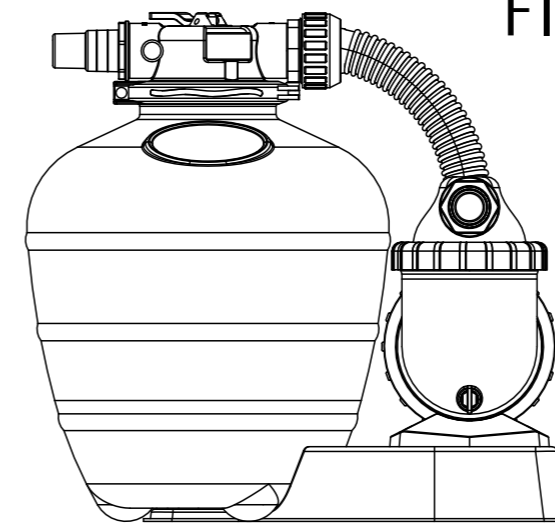

INSTALLATION

- * Install filtration system including pump, filter tank and multiport valve.
- * The filter system should be installed as close as possible to the swimming pool and preferably at a level of 0.50 metres below the surface of the water in the swimming pool. Make sure there is drainage available at the place where the filter is to be installed.
- * PUMP
 1. Only qualified, licensed personnel should install pump and wiring.
 2. Electrical Contractors Please Note: All 220 volt 60Hz pump must be wired to the main power supply through an approved and correctly rated contractor.
 3. Allow for gate valve in suction piping.
 4. Pump suction and discharge connections have moulded in thread stops, do not try to screw pipe in beyond these stops.
- * FILTER TANK and MULTIPOINT VALVE
 1. Loading the sand media. Filter sand media is loaded through the top opening of the filter.
 - a. Loosen the plastic clamps from tank neck.
 - b. Cap internal pipe with plastic cap to prevent sand from entering it.
 - c. We recommend filling tank approximately 1/2 way with water to provide a cushion effect when the filter sand is poured in. This helps protect the under-drain laterals from excessive shock.
 - d. Carefully pour in correct amount and grade of filter sand. Be sure center pipe remains centered in opening. Sand surface should be leveled and should come to about the middle of the filter tank. Remove plastic cap from internal pipe.
 2. Assemble filter control valve to filter tank.
 - a. Insert filter control valve (with O-ring in place) into the tank neck, taking care that the center pipe slips into the hole in the bottom of the valve.
 - b. Place two plastic clamps around valve flange and tank neck and tighten just enough so that the valve may be rotated on tank for final positioning.
 - c. Carefully screw pressure gauge (with O-ring in place) into tapped hole in valve body. Do not over-tighten.
 - d. Connect pump to control valve opening marked PUMP with hose. After connections are made, tighten clamps with screwdriver, tapping around clamp with screwdriver handle to help seat valve flange clamp.
 3. Make return to pool pipe connection to control valve opening marked RETURN and complete other necessary plumbing connections, suction lines to pump, waste, etc.
 4. To prevent water leakage, be sure all pipe connections are tight.

- ❖ Release all air from filter and piping system.
- ❖ In a flooded suction system (water source higher than pump), pump will prime itself when suction and discharge valves are opened.
- ❖ If pump is not in a flooded suction system, unscrew and remove trap cover; fill trap and pump with water.
- ❖ Clean and inspect Ring; re-install on trap cover.
- ❖ Replace trap cover on trap; turn clockwise to tighten cover.

NOTICE: Tighten trap cover by hand only. Pump should prime now. Priming time will depend on vertical length of suction lift and horizontal length of suction piping.

INSTALL/START-UP OF FILTRATION

1. Be sure correct amount of filter media sand is in tank and that all connections have been made and are secure.
2. Depress control valve handle and rotate to BACKWASH position. (To prevent damage to control valve seal, always depress handle before turning.)
3. Prime and start pump. Never run pump dry! Running pump dry may damage seals, causing leakage and flooding! Fill pump with water before starting motor. (be sure all suction and return lines are open), allowing the filter tank to fill with water. Once water is flowing out of the waste line, run the pump for at least 1 minute. The initial back-washing of the filter is recommended to remove any impurities or fine sand particles in the sand media.
4. Turn pump off and set valve to RINSE position. Start pump and operate until water in sight glass is clear, about 1/2 to 1 minute. Turn pump off and set valve to FILTER position and restart pump. The filter is now operating in the normal filter mode, filtering dirt particles from the pool water.
5. Adjust pool suction and return valves to achieve desired flow. Check system and filter for water leaks and tighten connections, bolts, nuts, as required.
6. Note the initial pressure gauge reading when the filter is clean. (It will vary from pool to pool depending upon the pump and general piping system.) As the filter removes dirt and impurities from the pool water, the accumulation in the filter will cause the pressure to rise and flow to diminish. When the pressure gauge reading is 1.5 bar, higher than the initial "clean" pressure you noted, it is time to backwash the filter (see BACKWASH under filter and control valve functions).

NOTE: During initial clean-up of the pool water it may be necessary to backwash frequently due to the unusually heavy initial dirt load in the water.

REPLACEMENT PARTS OF FILTER

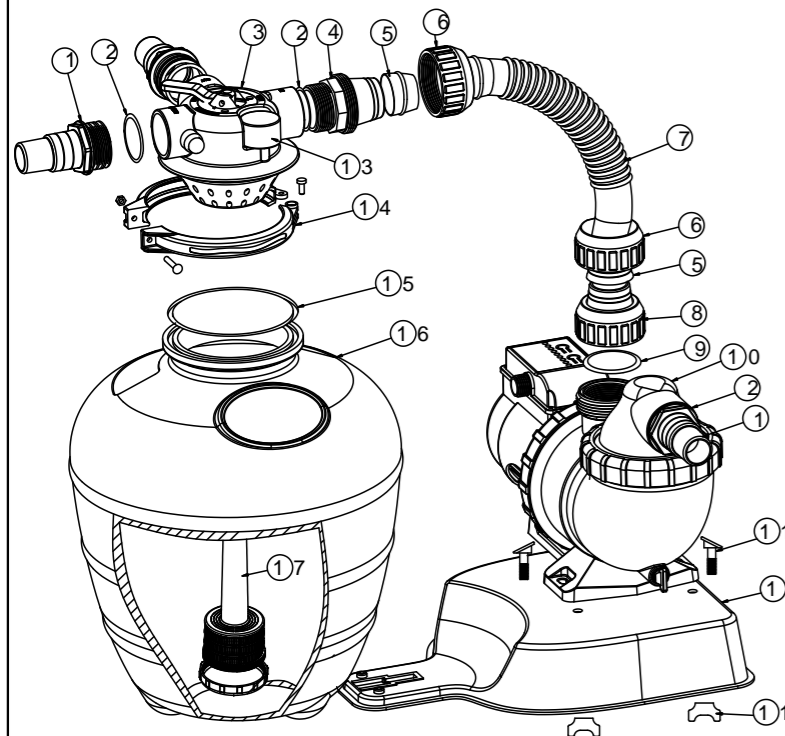

Item No.	Part No.	Description English	Qty
1	01013051	32mm 88mm Adaptor	3
2	02020013	O -Ring	4
3	88281105	4 Way Valve	1
4	01013047	Hose adaptor	1
5	02011026	Sleeve for Hose	2
6	01013046	Nut for Hose	2
7	01370011	Hose	1
8	01013049	Hose adaptor with nut	1
9	02011104	O -Ring	1
10	88028319	AMU012TP AQUA -MINI Pump (with timer & pre-filter)	1
	88027719	AMU012P AQUA -MINI Pump (with pre-filter)	1
	88028320	AMU016TP AQUA -MINI Pump (with timer & pre-filter)	1
	88027720	AMU016P AQUA -MINI Pump (with pre-filter)	1
	88028301	AMU020TP AQUA -MINI Pump (with timer & pre-filter)	1
	88027701	AMU020P AQUA -MINI Pump (with pre-filter)	1
11	89033601	Pump Assembly Screw	1
12	01111105	Combo Base	1
13	06021014	Plastic Pressure Gauge With O -Ring (8psi)	1
14	89033602	Clamp Lock with Screws & Nut	1
15	02010045	O -Ring	1
16	01331061	13 " Filter Tank	1
17	89033603	Lateral Assembly with Center Pipe	1

AMU PUMP REPLACEMENT PARTS

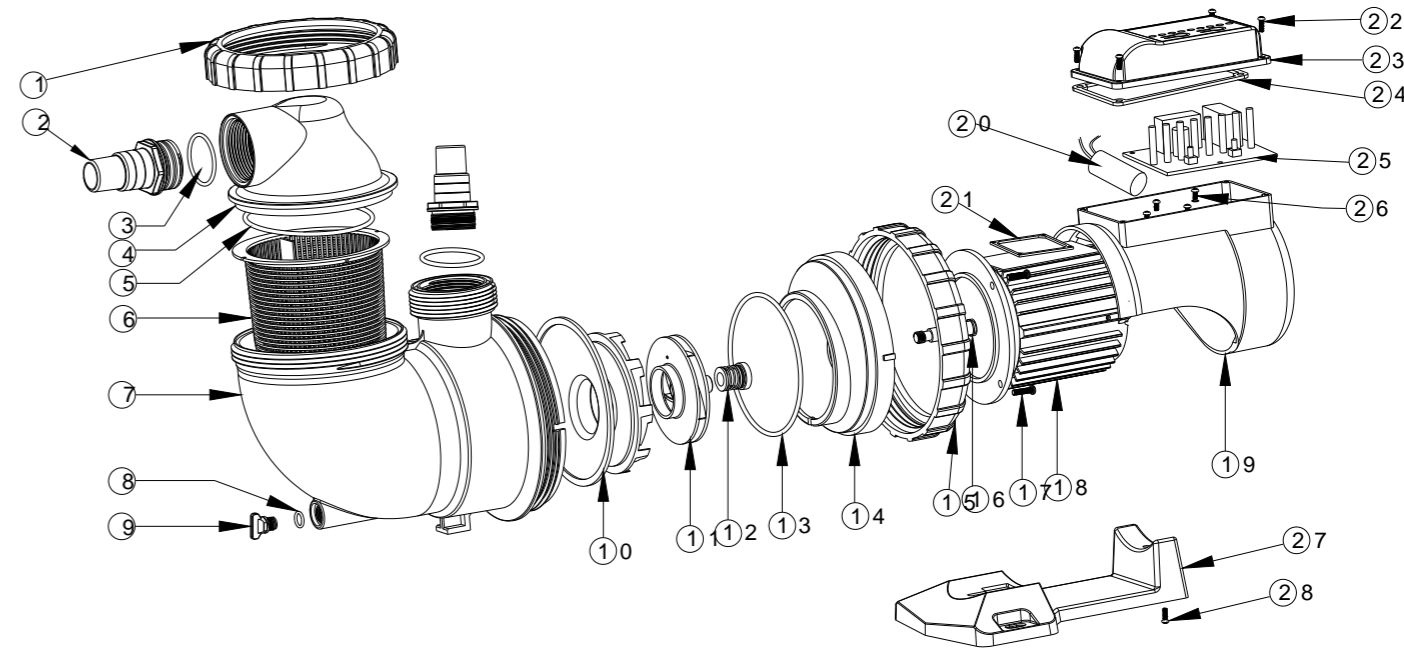

Item No.	Part No.	Description English	Qty	Item No.	Part No.	Description English	Qty	
1	01021067	Nut for lid	1	14	01021069	Flange	1	
2	89280105	1.5 "union (optional)	2	15	01021068	Nut for body	1	
	01013015	1.5 "Connector (for input)	1	16	02011156	Motor Slinger	1	
	01013051	32 -38 Union (optional)	2	17	03011067	Screw for flange	4	
3	02011104	O -Ring for 1.5 " Union	2	18	04020099	Motor (AMU012TP /AMU012P) (220V /50HZ) (220V /60HZ)	1	
	02020013	O -Ring for 32 -38 Union	2		04020100	Motor (AMU016TP /AMU016P) (220V /50HZ) (220V /60HZ)	1	
	01041045	Transparent Lid	1		04020101	Motor (AMU020TP /AMU020P) (220V /50HZ) (220V /60HZ)	1	
4	01041045	Transparent Lid	1	19	01321019	Fan Cover	1	
5	02020049	O -Ring for lid	1	20	04016036	Capacitor for AMU012TP /AMU012P &AMU016TP /AMU016P (220V /50Hz , 220V /60Hz)	1	
6	01111104	Basket	1		04016030	Capacitor for AMU020TP /AMU020P (220V /50Hz , 220V /60Hz)	1	
7	01021070	AMU pump body	1		21	02020048	Cover Slinger	1
8	02020014	O -Ring	1	22	03011007	Screw for cable Box	4	
9	01111017	Drain Plug	1	23	01321018	Cable Box	1	
10	01111103	Diffuser	1	24	02020012	Slinger for cable Box	1	
11	01311051	Impeller (AMU012TP /AMU012P) 220V /60HZ)	1		25	04015041	PCB for AMU012TP AMU016TP AMU020TP)	1
	01311045	Impeller (AMU016TP /AMU016P) 220V /60HZ)	1			26	03011100	Screw
	01311046	Impeller (AMU020TP /AMU020P) 220V /60HZ)	1	27			01111102	Base
12	04015002	1 /2 Mechanical seal	1		28	03011006	Screw for base	1
13	02020011	O -Ring for flange	1					

PRIMING PUMP

⚠ WARNINGS:

- *EMAUX pumps must be wired to the main supply through an approved and licensed electrician .
- *If the supply cord is damaged, it must be replaced by the manufacturer, its service agent or similarly qualified persons in order to avoid a hazard;
- *This appliance is not intended for use by persons including children with reduced physical, sensory or mental capabilities, lack of experience and knowledge, unless they are under supervision or instruction concerning safe use of the appliance by a person responsible for their safety; children should be supervised to ensure that they do not play with the appliance;
- *The maximum total head is 1 metre;
- *Pollution of the liquid could occur due to leakage of lubricants;
- *The pump must not be used when people are in the water;
- *The pump must be supplied through a residual current device(RCD) having a rated residual operating current not exceeding 30 mA.